



Installation Instructions

18SP557—Install ITT Conoflow™ Coolant Bowl Seal Kit 23530709

Introduction

Service kit 23530709 is intended for use on the ITT Conoflow™ first stage coolant regulator valve installed on natural gas-fueled Detroit Diesel Series 50®/Series 60® parlor coach or transit coach engines. The kit includes the items listed in Table 1.

Description	Qty.
O-Ring Seal, Large	1
O-Ring Seal, Small	1
Installation Instructions	1

Table 1. Service Kit 23530709 Parts List

Kit Installation

Install the seal kit as follows:



CAUTION:

To avoid injury from hot surfaces, allow the engine to cool before removing any component. Wear protective gloves.



CAUTION:

To avoid injury from accidental engine start-up while servicing the engine, disconnect/disable the starting system.



CAUTION:

To avoid injury from the expulsion of hot coolant, never remove the cooling system pressure cap while the engine is at operating temperature. Remove the cap slowly to relieve pressure. Wear adequate protective clothing (face shield or safety goggles, rubber gloves, apron, and boots).

1. With the engine at ambient temperature (cool to the touch) and the starting system disconnected/disabled, place a suitable clean container under the radiator and drain the cooling system to the level just below the regulator valve bowl. If coolant is not to be reused, dispose of it in an environmentally responsible manner, according to state and/or federal recommendations.
2. Note the installed position of the coolant bowl on the pressure-reducing regulator body and the locations of the fittings in the coolant bowl. Scribe the bowl and body with a match mark, if necessary. See Figure 1.
3. Disconnect coolant hoses from the fittings at the bottom of the bowl.
4. Remove the bowl-retaining screw and seal and pull the bowl straight down and away from the regulator body.
5. Remove and discard the small O-ring on the screw and the large O-ring on the regulator body.
6. Clean the O-ring groove in the regulator body. Ensure the O-ring sealing surfaces are clean and free of residual sealing material.

7. Use a soap and water solution to check the regulator inlet gas pressure cap for bubbles, indicating a gas leak. *If gas leakage is indicated, replace the regulator assembly.* See Figure 1.
8. Apply a light film of petroleum-base grease to the large and small O-rings. Fit the large O-ring into the regulator body seal groove. Place the small O-ring onto the bowl retaining screw.
9. Install the bowl into the regulator body by pushing straight up *without twisting*. Ensure the bowl is fully seated over the O-ring and is centered over the machine screw threads in the bottom.

NOTICE:

Do not twist the bowl during installation, since this may cut the O-ring, resulting in a leak.

10. Install the retaining screw/seal assembly into the bowl and torque to 6.8 N•m +/- 0.7 N•m (60 lb-in +/- 6 lb-in) using a 7/32-in. hex key socket.
11. Reconnect hoses to the fittings at the bottom of the bowl and fill the cooling system.



CAUTION:

Diesel engine exhaust and some of its constituents are known to the State of California to cause cancer, birth defects, and other reproductive harm.

- **Always start and operate the engine in a well-ventilated area.**
- **If operating an engine in an enclosed area, vent the engine to the outside.**
- **Do not modify or tamper with the exhaust system or emission control system.**

12. Reconnect starting power, start the engine, and check for leaks.

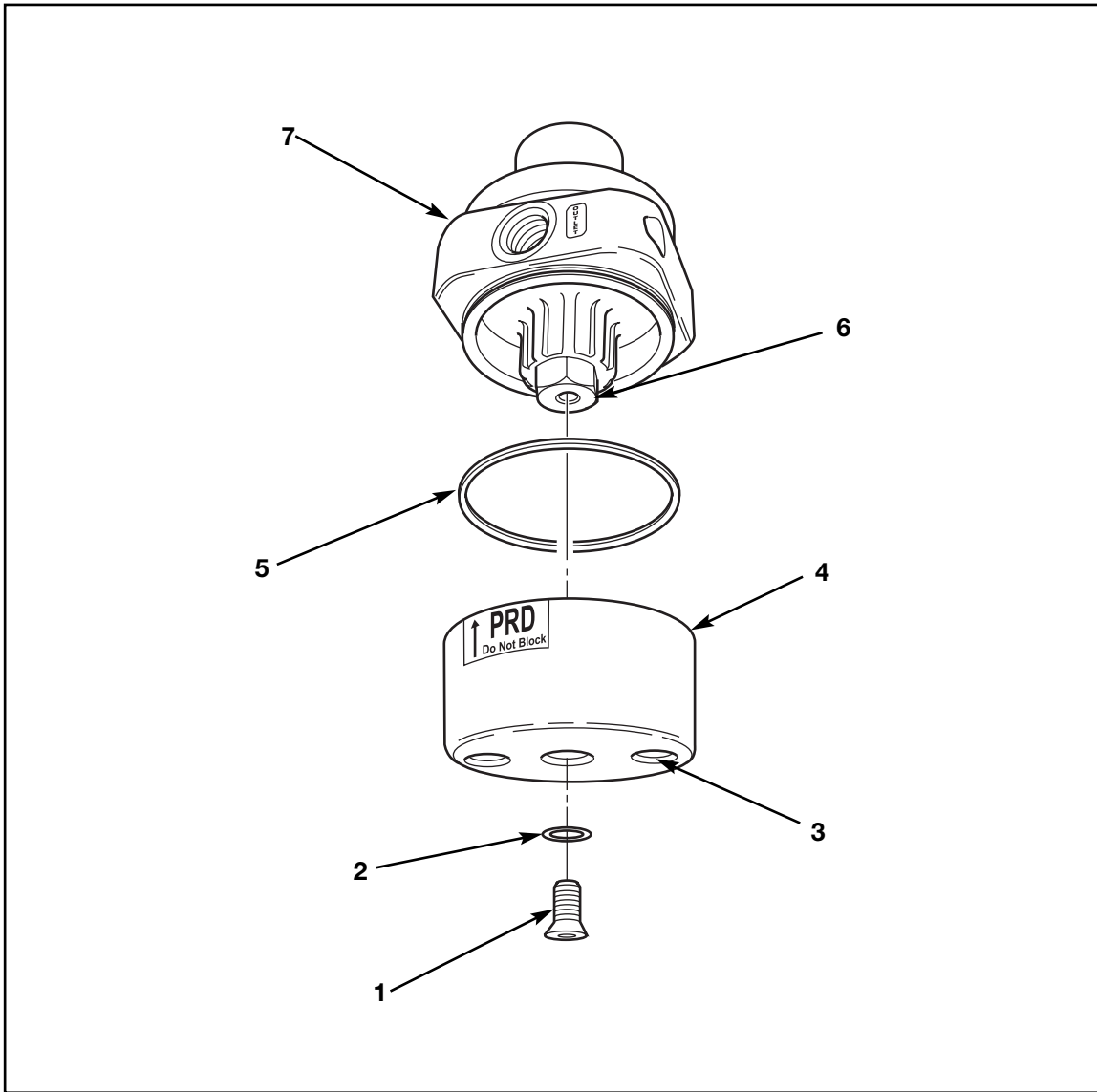

- 1. Coolant Bowl Retaining Screw
- 2. Small O-Ring
- 3. Coolant Port
- 4. Coolant Bowl

- 5. Large O-Ring
- 6. Inlet Gas Pressure Cap
- 7. Regulator Body

Figure 1. ITT Conoflow First Stage Regulator

DETROIT DIESEL



13400 Outer Drive, West, Detroit, Michigan 48239-4001
Telephone: 313-592-5000
www.detroitdiesel.com

18SP557 Page 4 of 4

Detroit Diesel®, the spinning arrows design, Series 50® and Series 60® are registered trademarks of Detroit Diesel Corporation.
Conoflow® is a registered trademark of ITT Industries.

18SP557 0204 Copyright © 2002 Detroit Diesel Corporation. All rights reserved. Printed in U.S.A. All specifications subject to change without notice.