

DETROIT DIESEL



Installation Instructions

18SP578 – Injector Seal Ring Replacement Kit P/N: 23533294 for the Series 60[®] 2004 EGR Engine

Introduction

The new N3 injector released on 2004 EGR Series 60 engines has three o-rings and one copper seal. All of these o-rings and the seal are to be used **one time only**.

Installation

Every time an injector is removed and reinstalled from the cylinder head, the o-rings and seal are to be replaced by using the injector seal ring kit, part number 23533294. If injectors are changed, then the used o-rings and seal should remain on the removed injectors, and returned under the normal process.

The copper seal is vital to providing proper sealing from cylinder combustion gas migrating past the injector tip and attacking the o-ring seals on the injector, as well as the o-ring seal of the injector cup insert. The contoured side of the copper seal is to be installed in the up position against the injector. This provides a carbon collection area to maintain a cleaner surface between the copper seal and the injector cup insert. See Figure 1.

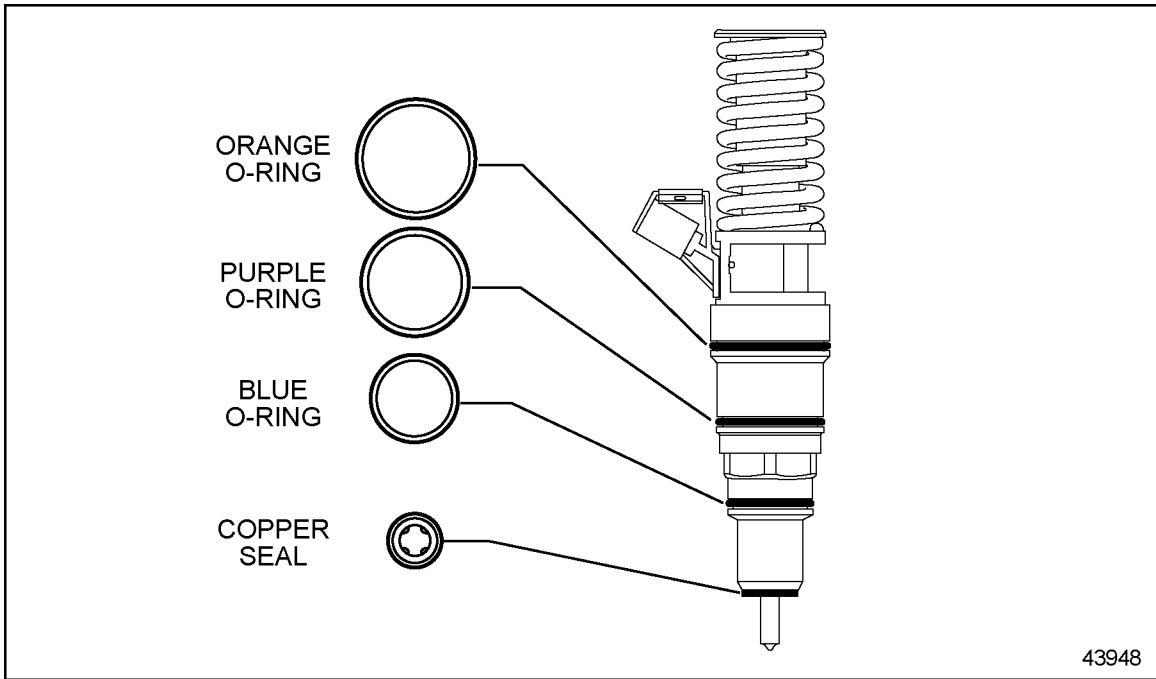

Figure 1 Injector Seal Ring Replacement Kit P/N 23533294

DETROIT DIESEL



13400 Outer Drive, West, Detroit, Michigan 48239-4001
Telephone: 313-592-5000
www.detroitdiesel.com

Copyright© 2003 Detroit Diesel Corporation. Detroit Diesel®, DDC®, Series 60® and the spinning arrows design are registered trademarks of Detroit Diesel Corporation. All other trademarks are the property of their respective owners.
18SP578 0311 As technical advances continue, specifications will change. All rights reserved. Printed in U.S.A.