



## Installation Instructions

### 18SP629 – MBE4000 EGR Connector Pipe Installation

#### KIT DESCRIPTION

A new service kit (P/N: 23536463) is now available to install an EGR connector pipe and sealing rings on MBE4000 engines.

#### **NOTICE:**

This kit should only be used on EGR engines prior to unit serial number 0460833653.

#### KIT CONTENTS

This kit contains the parts listed in Table 1.

Part Number	Quantity	Description
4601400048	1	EGR Connector Pipe
0001427857	2	Seal Ring
0009941718	2	Wave Spring
18SP629	1	Installation Instructions

**Table 1** Content for Service Kit (P/N: 23536463)

#### INSTALLATION PROCEDURE

Install the bracket as follows (see Figures 1-5):

#### **WARNING:**

#### **PERSONAL INJURY**

**To avoid injury before starting and running the engine, ensure the vehicle is parked on a level surface, parking brake is set, and the wheels are blocked.**

1. Loosen and remove the outside nut that is resting on the outside face of the stud bracket.  
See Figure 1.

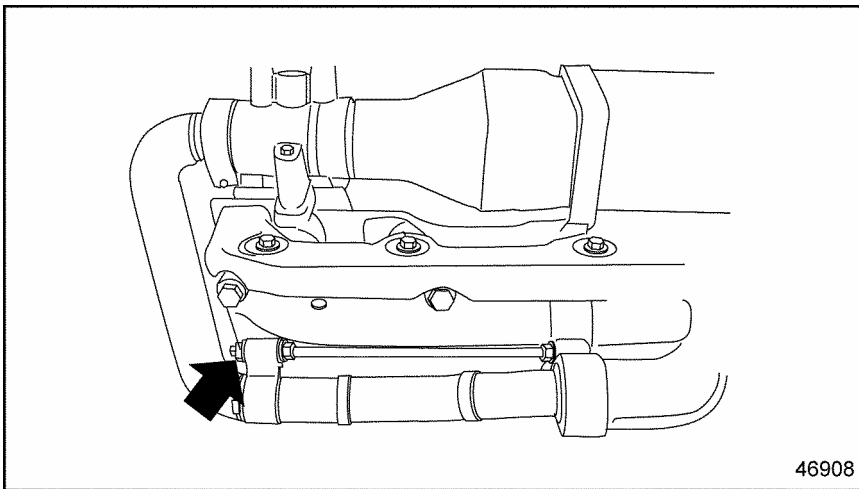

**Figure 1 Nut on Stud Bracket**

2. Loosen and remove the bolt from the positioning clamp which holds the gas inlet pipe to the throttle shutoff valve and remove the clamp. See Figure 2.

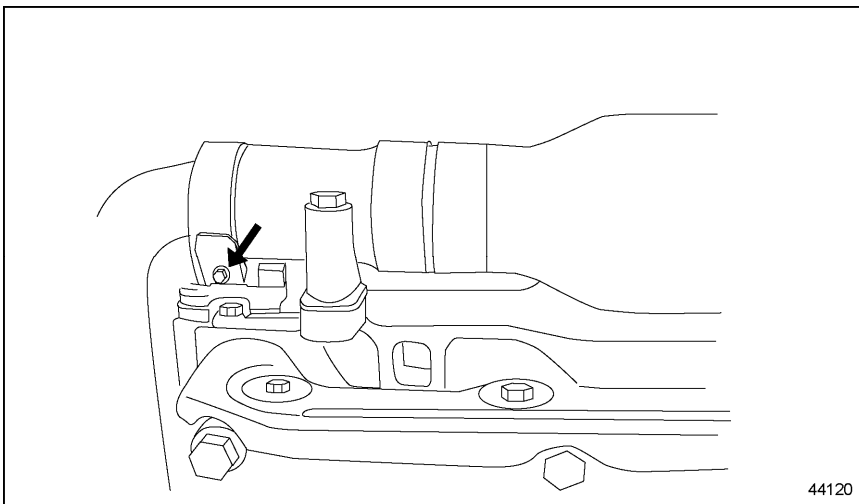

**Figure 2 Positioning Clamp**

3. Gently pull the gas inlet pipe from the center piece of the exhaust manifold and the throttle shutoff valve. Note the arrows highlighting the affected areas in Figure 3.

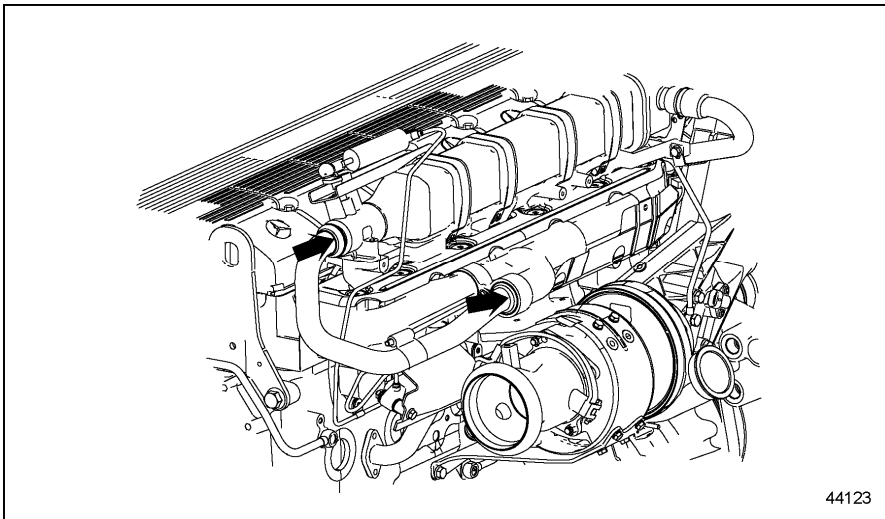

**Figure 3 Gas Inlet Pipe**

4. Remove the air supply line to the throttle shutoff valve actuator. See Figure 4.



**Figure 4 Air Supply Line to Throttle Shutoff Valve Actuator**

5. Remove the two throttle shutoff valve mounting bolts and then the throttle shutoff valve. See Figure 5.

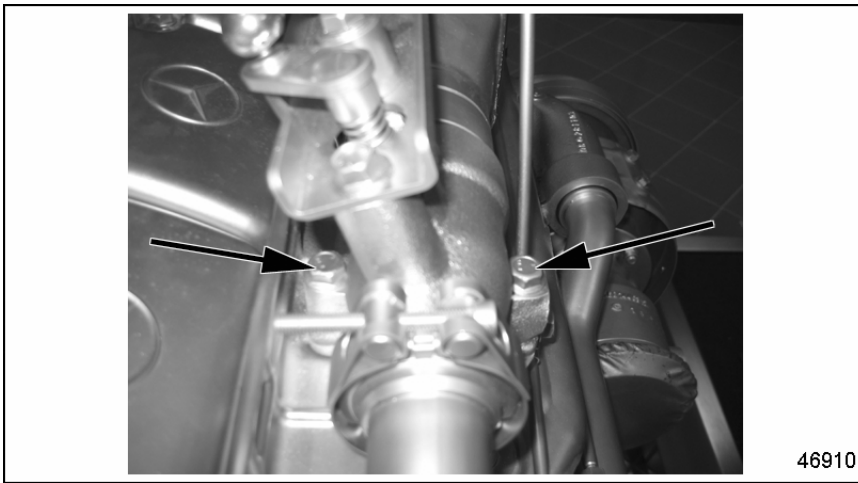

**Figure 5 Throttle Shutoff Valve Mounting Bolts**

6. Slide out the EGR connector pipe from the EGR cooler.
7. Install one of the wave springs into the EGR cooler inlet. Make sure the flat side of the wave spring is facing out. See Figure 6.

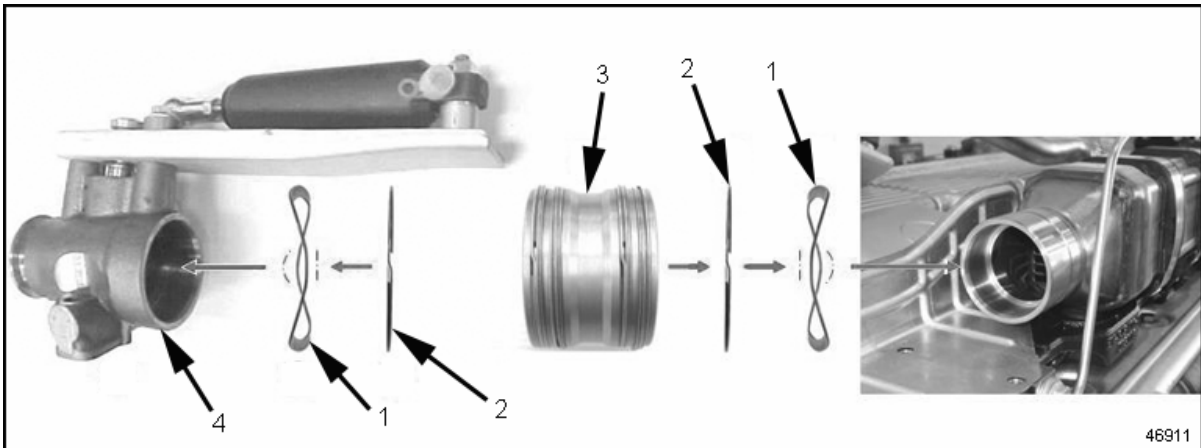

- |  |  |
|--|--|
| <ol style="list-style-type: none"> <li>1. Wave Spring</li> <li>2. Seal Ring</li> </ol> | <ol style="list-style-type: none"> <li>3. EGR Connector Pipe</li> <li>4. Throttle Shutoff Valve</li> </ol> |
|--|--|

**Figure 6 EGR Connector Pipe Assembly**

8. Install one of the seal rings into the EGR cooler inlet against the flat side of the wave spring. See Figure 6.
9. Inspect the EGR connector pipe assembly BEFORE installing it. There are four grooves on the connector pipe assembly – two on each end.

## NOTICE:

To avoid connector pipe damage, the Fey rings **must** be installed according to directions.

- Each groove contains two Fey rings, so there are a total of eight Fey rings.
  - Within each groove, make sure the Fey rings are staggered 180 degrees from each other.
  - Make sure the Fey ring set in each groove are staggered 180 degrees from the Fey ring set in the neighboring groove.
  - The net effect is the Fey ring gaps are staggered 90 degrees at each end of the pipe assembly.
10. Install the new EGR connector pipe assembly into the EGR cooler.
  11. Install the other wave spring into the throttle shutoff valve. Make sure the flat side of the wave spring is facing out. See Figure 6.
  12. Install the other seal ring into the throttle shutoff valve against the flat side of the wave spring. See Figure 6.
  13. Slide the throttle shutoff valve onto the new EGR connector pipe assembly. See Figure 6.
  14. Install the two throttle shutoff valve mounting bolts and torque them to 35 N·m (26 lb·ft). See Figure 5.
  15. Install the air supply line to the throttle shutoff valve actuator and torque the nut to 25 N·m (18 lb·ft). See Figure 4.
  16. Gently install the gas inlet pipe into the center section of the exhaust manifold and the throttle shutoff valve. See Figure 3.
  17. Install the positioning clamp and hand tighten the bolt. See Figure 2.
  18. Install the outside nut on the stud bracket and torque to 25 N·m (18 lb·ft). See Figure 7.
  19. Check the length of the stud and verify it is 219 mm (8.62 in). If not, adjust the stud to 219 mm (8.62 in). Reference the *MBE4000 Service Manual* (6SE412). See Figure 7.

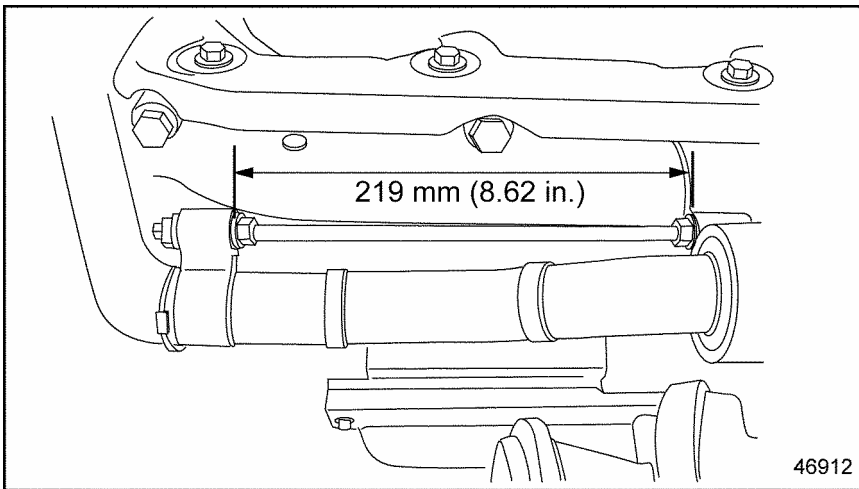

**Figure 7 Stud Adjustment**

20. Torque the positioning clamp to 12 N·m (9 lb·ft). See Figure 2.

 **WARNING:**

### PERSONAL INJURY

**Diesel engine exhaust and some of its constituents are known to the State of California to cause cancer, birth defects, and other reproductive harm.**

- **Always start and operate an engine in a well ventilated area.**
- **If operating an engine in an enclosed area, vent the exhaust to the outside.**
- **Do not modify or tamper with the exhaust system or emission control system.**

21. After all repairs are complete, start and run the engine to ensure it is operating properly.

**DETROIT DIESEL**



13400 Outer Drive, West, Detroit, Michigan 48239-4001  
Telephone: 313-592-5000  
[www.detroitdiesel.com](http://www.detroitdiesel.com)

Copyright© 2006 Detroit Diesel Corporation. Detroit Diesel®, DDC®, DDEC®, Series 60® and the spinning arrows design are registered trademarks of Detroit Diesel Corporation. All other trademarks are the property of their respective owners.  
**18SP629 0602 As technical advances continue, specifications will change. All rights reserved. Printed in U.S.A.**